

1 Goupille de sécurité marche avant
Shear pins forward

3 Support de vérin
Ram fixing bracket

2 Entrée de câble
Rope guide

4 Vérin VA2
Hydraulic ram VA2

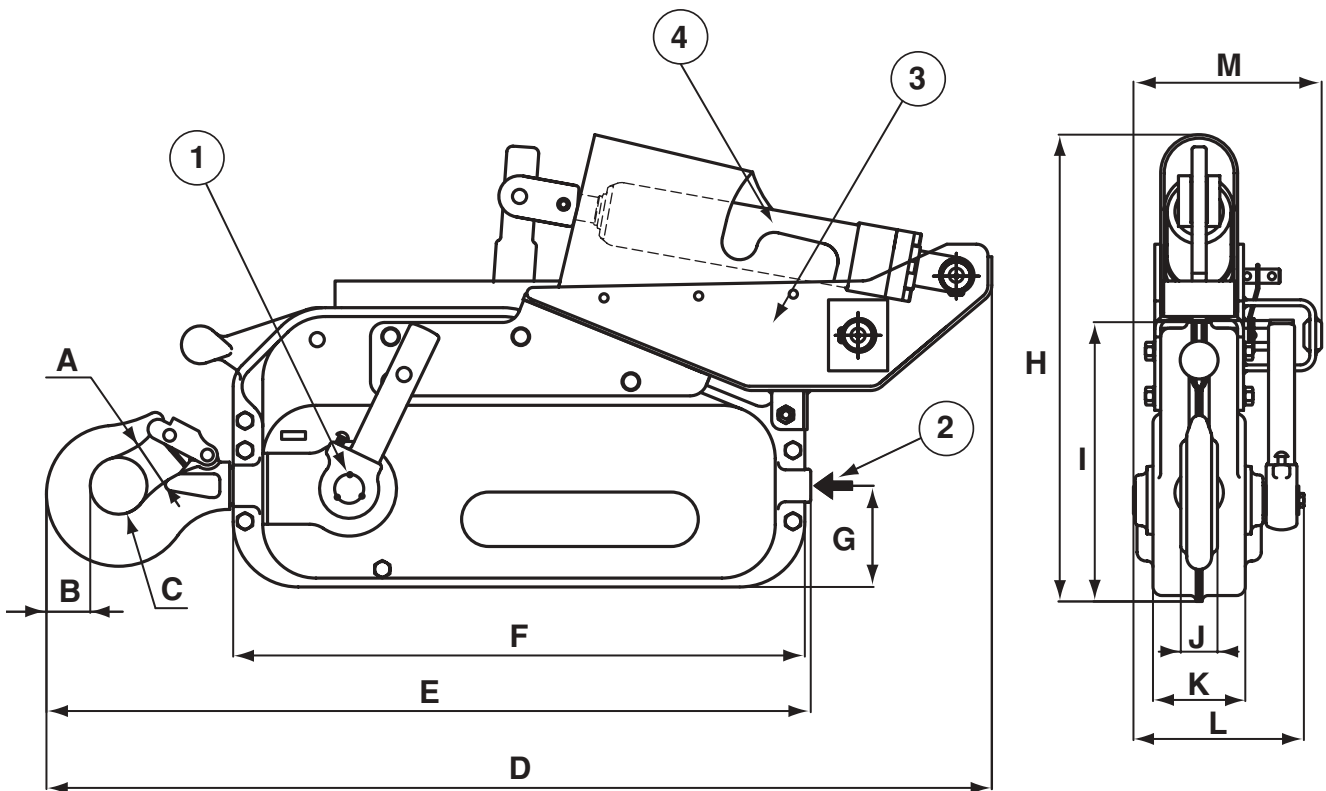

C.M.U.	Ø câble	Effort au levier*		Avance du câble*		Dimensions mm													Poids
W.L.L.	Ø wire rope	Effort to control lever*		Rope travel*		Dimensions mm													Weight
daN/kg	mm	M. avant / forward kg	M. arrière / reverse kg	M. avant / forward mm	M. arrière / reverse mm	A	B	C	D	E	F	G	H	I	J	K	L	M	kg
1 600	11,5	54	20	56	70	38	36	48	800	646	483	86	400	236	31	78	144	160	30

* C.M.U. nominale

* Nominal W.L.L.

- 1** Goupille de sécurité marche avant
Shear pins forward
- 2** Entrée de câble
Rope guide
- 3** Support de vérin
Ram fixing bracket
- 4** Vérin VA3
Hydraulic ram VA3

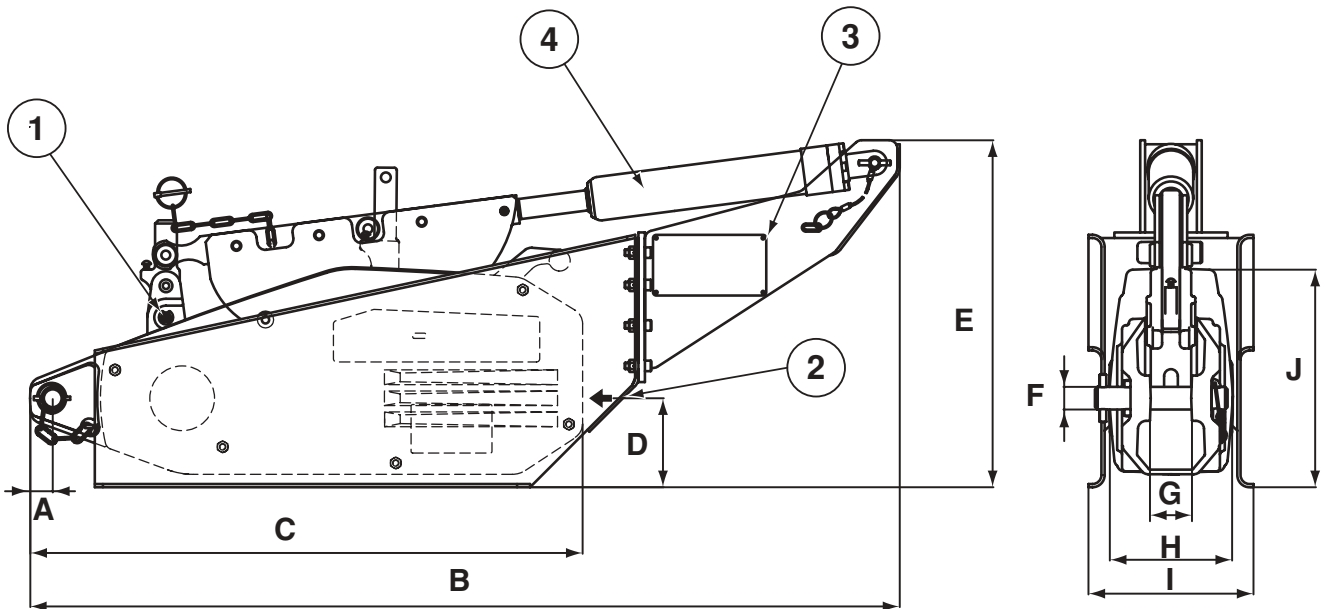

C.M.U.	Ø câble	Effort au levier*		Avance du câble*		Dimensions mm										Poids
W.L.L.	Ø wire rope	Effort to control lever*		Rope travel*		Dimensions mm										Weight
daN/kg	mm	M. avant / forward kg	M. arrière / reverse kg	M. avant / forward mm	M. arrière / reverse mm	A	B	C	D	E	F	G	H	I	J	kg
3 200	16,3	54	25	30	48	28	1070	680	110	430	28	50	150	205	270	56

* C.M.U. nominale
* Nominal W.L.L.